



WESTWAARD

The future of your farm starts with a healthy calf...



CALF FEEDING PRODUCT LINE

PASTEURIZERS



Part # WP20G

20 GALLON CAPACITY

- Pump Agitation and Dispense System
- Automated Pasteurization Cycles with Large PLC Screen
- Re-Heat & Pre-Cool Options Standard
- Programs for Colostrum Pasteurization and Colostrum Thaw for Frozen Bags
- Manual Wash
- Electric Heating
- 30 Amp 240VAC
1 Phase 4-Wire

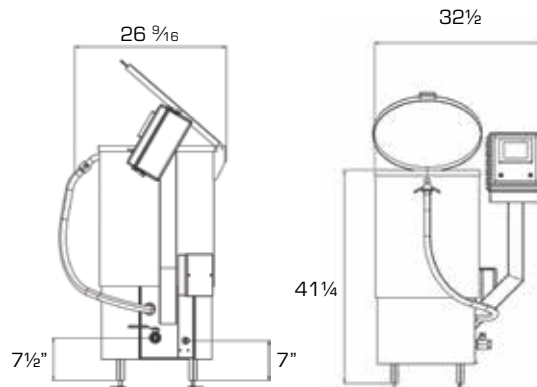

40/60/90 GALLON CAPACITY

- Pump Agitation and Dispense System
- Automated Pasteurization Cycles with Large PLC Screen
- Re-Heat & Pre-Cool Options Standard
- Programs for Colostrum Pasteurization and Colostrum Thaw for Frozen Bags
- Automatic C.I.P. System
- Optional Peristaltic Chemical Pump
- Electric Heating
- 40 Gallon - 40 Amp 240VAC 1 Phase 4-Wire
- 60 Gallon - 60 Amp 240VAC 1 Phase 4-Wire
- 90 Gallon - 80 Amp 240VAC 1 Phase 4-Wire



40 Gallon Part # WP40G

60 Gallon Part # WP60G

90 Gallon Part # WP90G

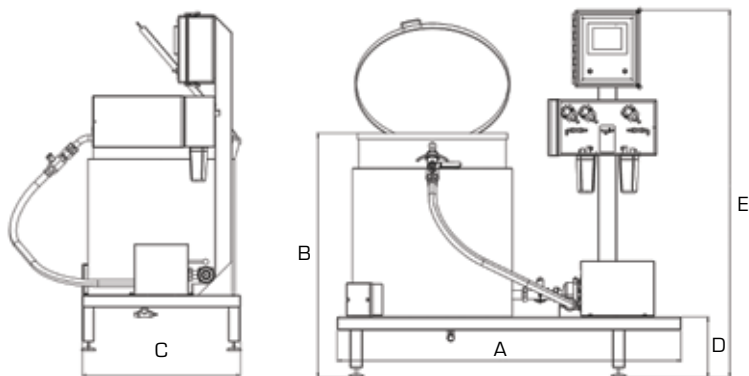

Basic Dimensions:

	A	B	C	D	E
WP40G	56	39 ⁵ / ₈	28	9 ³ / ₄	59 ⁵ / ₈
WP60G	56 ¹ / ₄	42	30 ¹ / ₄	9 ³ / ₄	59 ⁵ / ₈
WP90G	62 ¹ / ₂	42 ⁷ / ₈	34 ¹ / ₈	9 ³ / ₄	59 ⁵ / ₈



120/150/200/250 GALLON



- Pump Agitation and Dispense System
- Automated Pasteurization Cycles
- Re-Heat & Pre-Cool Options Standard
- Automatic C.I.P. System
- Peristaltic Chemical Pump
- Large PLC Screen Provides Information Throughout Cycles
- Requires Integration with Hot Water Heater for Heating Cycle
- 20 Amp 240VAC 1 Phase 4-Wire

120 Gallon Part # WP120G
 150 Gallon Part # WP150G
 200 Gallon Part # WP200G
 250 Gallon Part # WP250G

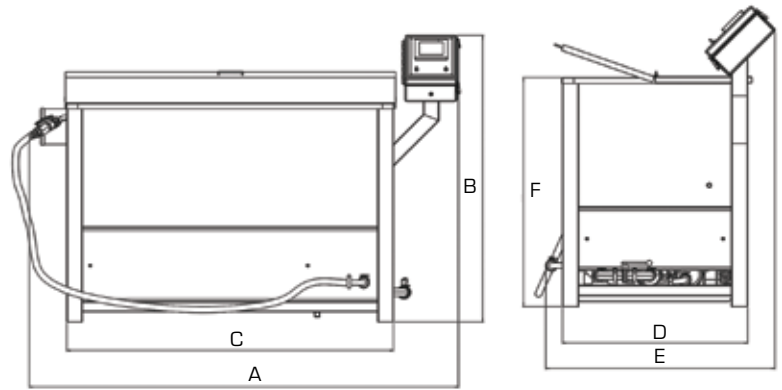

Basic Dimensions:

	A	B	C	D	E	F
WP120G	71 1/8	55 5/8	51 1/4	34 1/4	42 3/8	42 1/2
WP150G	83 1/8	55 5/8	63 1/4	34 1/4	42 3/8	42 1/2
WP200G	102 1/8	55 5/8	82 1/4	34 1/4	42 3/8	42 1/2
WP250G	118 1/8	55 5/8	98 1/4	34 1/4	42 3/8	42 1/2

DELIVERY:

Single Dispense Nozzle

WP20G only



Multi-Dispense Fork
 WP40G-WP250G

PLC Control Box

With our in-house custom-built PLC panels, controlling your pasteurizer or bottle washer is easier than ever! Our touch screen control allows full set-ability of all functions from wash cycles to re-heat and pre-cool pasteurization cycles. Offering the reliability and functionality of the industrial PLC control system.



INCLUDED MIXING/CLEANING ATTACHMENTS:



Spray Ball
 Switch out for cleaning cycle



Agitation Tube
 For circulation during the pasteurization process

PASTEURIZERS

PASTEURIZER CONTROL CENTER ASSEMBLY

The Control Center Assembly pasteurizers allow integration to large agitated batch tank. They do all the tie-ins between tank and boilers or hot water heater. Typically used for connection with 300-800 gallon batch tank.

- Automatic Wash Cycle with Peristaltic Chemical Pump
- Includes PLC Control Box
- Milk Circulation/Unload Pump
- Hot Water Circulation Pump
- Water Control Solenoids
- Heat/Cool Exchanger
- Standard Model - 20 Amp, 240VAC single Phase 4-Wire
- High Capacity Model - 30 Amp, 240VAC single Phase 4-Wire

Model #	Pasteurizer Capacity
WPLGCC	Up to 450 Gallons
WPLGCCHC	Up to 800 Gallons



Part # WPLGCC

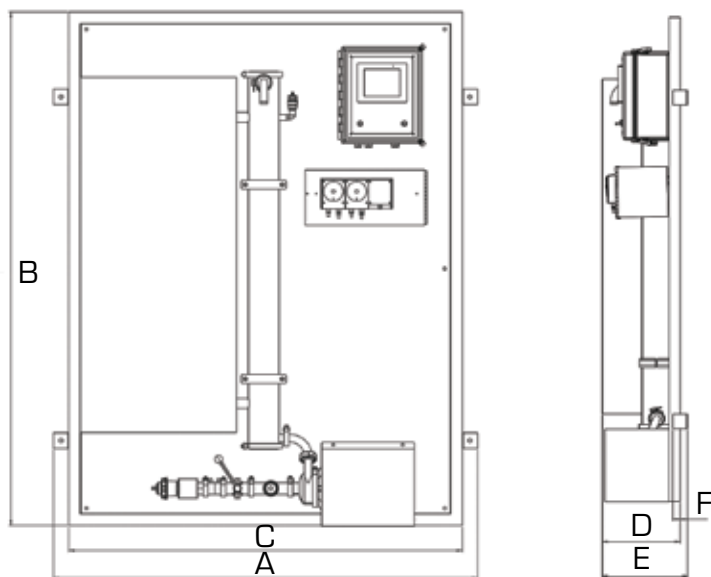

Basic Dimensions:

	A	B	C	D	E	F
WPLGCC	55	66 ½	51	10 ¾	11 ¾	2
WPLGCCHC	55	66 ½	51	10 ¾	11 ¾	2



Part # WPLGCCHC



CALF MILK BOTTLE & NIPPLE WASHER

While great effort is put into preparing milk the right way to feed calves, it is important that the sanitation of milk bottles is maintained to a high standard as well. Westward's bottle washer unit incorporates a nipple washing basin in varying sizes from 30 to 120 bottle capacity so you can clean and sanitize your calf bottles and nipples in one cycle with one piece of equipment!

With our years of equipment and automation experience, our goal is to give you the tools to raise the healthiest calves possible, while allowing you to do it in the most efficient and most economical method available.



Integrated Bottle/Nipple Washer

Model #	Bottle Capacity
WBW30	30 Bottles
WBW40	40 Bottles
WBW60	60 Bottles
WBW90	90 Bottles
WBW120	120 Bottles



Washer jet rails and water flow clean and sanitize nipples during the bottle wash cycle.



Easy loading grid features cone spray nozzles for clean spray and excellent bottle coverage.

Stand Alone Bottle Washer

Model #	Bottle Capacity
WBW150	150 Bottles
WBW200	200 Bottles

CALF MILK BOTTLE & NIPPLE WASHER WITH LID

Westward's optional lidded bottle washer unit also incorporates a nipple washing basin in varying sizes from 30 to 90 bottle capacity so you can clean and sanitize your calf bottles inside as well as outside in one wash with one piece of equipment!



Integrated Bottle/Nipple Washer with Lid

Model #	Bottle Capacity
WBW30L	30 Bottles
WBW40L	40 Bottles
WBW60L	60 Bottles
WBW90L	90 Bottles



Spinning washer wands clean and sanitize the outside during the bottle wash cycle.

INTEGRATED PASTEURIZER/WASH UNITS



Individual valve zone control for washing at less than full capacity.



Easy loading grid features cone spray nozzles for clean spray and excellent bottle coverage.



INTEGRATED PASTEURIZER/BOTTLE WASHER

Models and Capacity:

Model #	Pasteurizer Capacity	Bottle Capacity
WP40G30BW	40 Gallons	30 Bottles
WP40G40BW	40 Gallons	40 Bottles
WP40G60BW	40 Gallons	60 Bottles
WP60G40BW	60 Gallons	40 Bottles
WP60G60BW	60 Gallons	60 Bottles
WP60G90BW	60 Gallons	90 Bottles
WP90G60BW	90 Gallons	60 Bottles
WP90G90BW	90 Gallons	90 Bottles
WP90G120BW	90 Gallons	120 Bottles
WP120G90BW	120 Gallons	90 Bottles
WP120G120BW	120 Gallons	120 Bottles
WP120G150BW	120 Gallons	150 Bottles
WP150G120BW	150 Gallons	120 Bottles
WP150G150BW	150 Gallons	150 Bottles
WP150G200BW	150 Gallons	200 Bottles
WP200G150BW	200 Gallons	150 Bottles
WP200G200BW	200 Gallons	200 Bottles
WP250G150BW	250 Gallons	150 Bottles
WP250G200BW	250 Gallons	200 Bottles

Please contact us for dimensions and custom configuration options

Save time and money with an integrated calf milk pasteurizer and bottle washer unit! This combination offers materials cost savings with a shared control panel and shared chemical and wash pumps. VFD controls offer programmable pump speed settings for pasteurizer and wash cycles.



BOTTLE WASH UNITS DIMENSIONS

Integrated Bottle & Nipple Washer (30 - 120 Bottles)

Typical Dimensions:

	A	B	C	D
WBW30	34 1/8	47 3/4	23 7/16	92 1/2
WBW40	34 1/8	47 3/4	29 3/8	92 1/4
WBW60	34 1/8	47 3/4	35 1/16	102 7/8
WBW90	34 1/8	47 3/4	35 3/16	137 3/4
WBW120	34 1/8	47 3/4	45 3/16	159 7/16

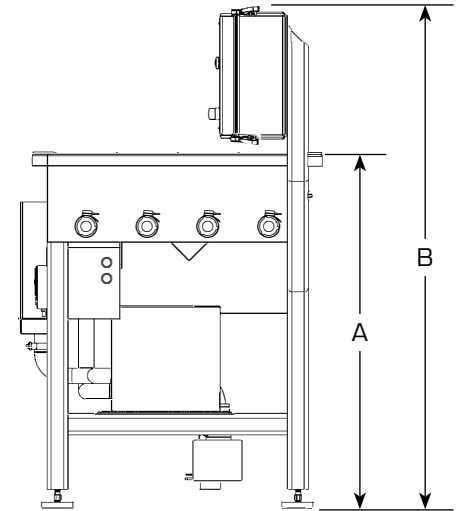
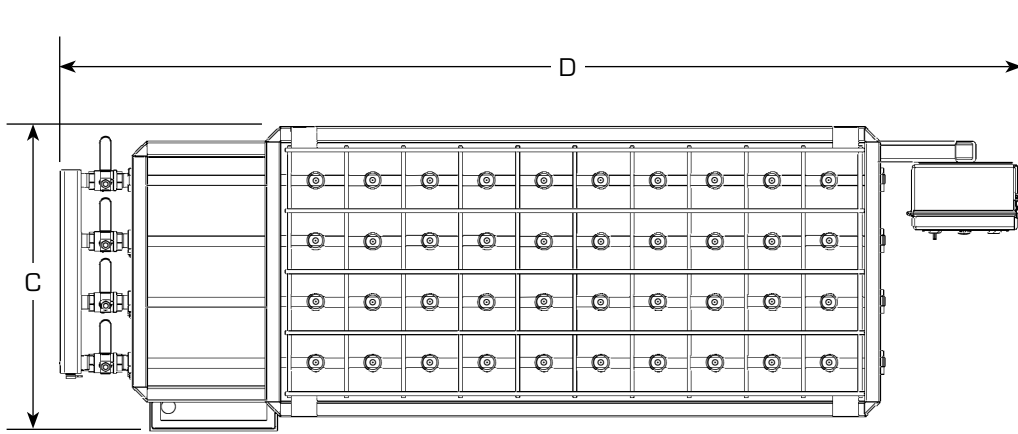

Stand Alone Bottle Washer (150 & 200 Bottles)

Typical Dimensions:

	A	B	C	D
WBW150	34 1/8	47 3/4	46 3/8	161 7/16
WBW200	34 1/8	34 1/8 *	47 7/16	200 9/16

*This unit does not include an attached control box

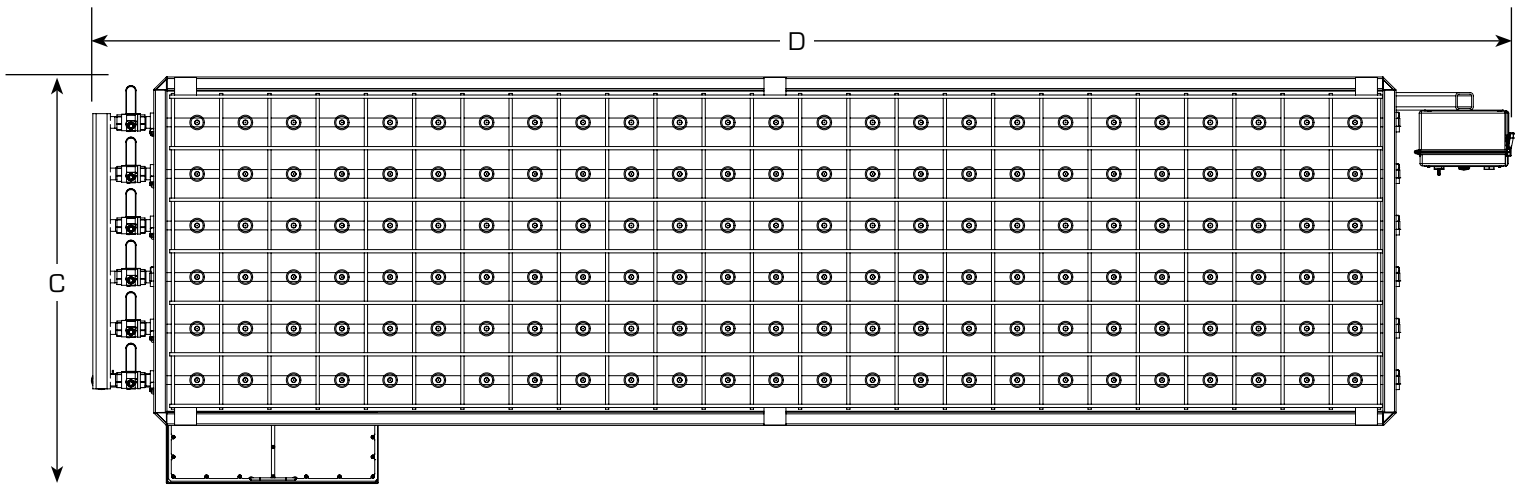
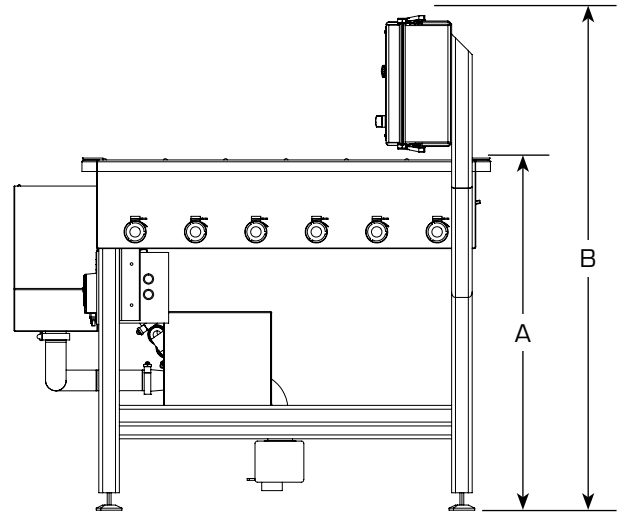

NIPPLE WASH UNITS

CALF MILK NIPPLE WASHER

With three different models, this stand-alone unit sanitizes and disinfects the calf bottle nipples. Capacities from 150 nipples to 600 nipples.

With our years of equipment and automation experience, our goal is to give you the tools to raise the healthiest calves possible, while allowing you to do it in the most efficient and most economical method available.



Models and Typical Dimensions:

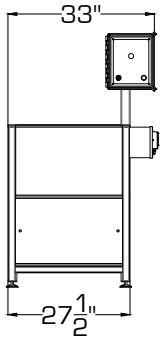

WNW 150

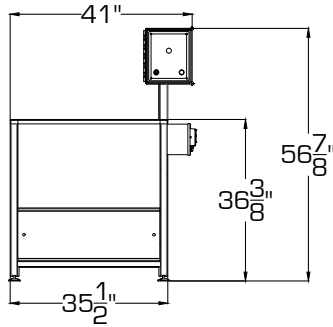

WNW 300

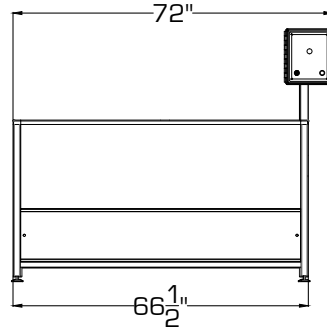

WNW 600



WESTWAARD

As custom fabricators for Daritech, we expertly craft highly polished stainless steel dairy accessories along with our calf feeding line of products. From milking claws, to back flush valves to CIP fold downs, we have over three decades of experience providing dairy farms with the stainless equipment they need.



Contact us today for more information on our entire line of products and for a dealer near you !

www.daritech.com

Phone: (800) 701-3632 or (360) 354-6900 • 8540 Benson Road • Lynden, WA 98264